

**DRUCK DPI 601  
PORTABLE PRESSURE INDICATOR/CALIBRATOR  
USER MANUAL**

**© Druck Limited 1995**

*This document is the property of Druck Limited and may not be copied or otherwise reproduced, communicated in any way to third parties, nor stored in any Data Processing System without the express written authority of Druck Limited.*

## SAFETY

This publication contains information and warnings that must be followed for the safe operation and to maintain the instrument in a safe condition. Use competent personnel and good engineering practice for all procedures and practices in this publication.

The operator must not use this instrument for any other purpose than that stated. Use the pressure medium stated in this publication; do not use any other medium without consulting DRUCK.

Do not apply a pressure greater than 150% of the full-scale pressure of the pressure range of the instrument. For the hydraulic actuator version this value is 130% of the full-scale pressure range of the unit. Applying an excessive pressure, greater than that stated, can cause injury, damage the instrument and the user system and equipment.

**Note:** *Abbreviations are the same in the singular and plural.*

A	Ampere
cc	cubic centimetre
COM	common (connection)
diff	differential
°C	degrees centigrade
°F	degrees Fahrenheit
DC	direct current
DP	decimal point
DPI	digital pressure indicator
DMM	digital multimeter
Err	error
FS	full-scale
GND	ground (earth)
Hz	Hertz
IEC	International Electrical Council
Iss	issue
kg	kilo-gram
kHz	kilo-Hertz
LCD	liquid crystal display
LK	link
mA	milli Ampere
mbar	milli bar
max	maximum
min	minimum
mm	milli-metre
mV	milli-Volt
M $\Omega$	mega ohm
$\mu$ A	micro Ampere
nA	nano Ampere
No.	number
$\Omega$	Ohm
PCB	printed circuit board
ref	reference
RV	variable resistor
SAE	Society of Automotive Engineers
sec	second
SIG	signal
SK	socket
UK	United Kingdom
USA	United States of America
V	Volt
VTX	transmitter voltage

## Contents

1	INTRODUCTION .....	1
1.1	Specification .....	1
2	INSTALLATION .....	5
2.1	Power Supply .....	5
2.2	Pneumatic Supply .....	6
3	OPERATION .....	7
3.1	Modes of Operation .....	7
3.2	Key Functions .....	7
3.3	Pressure Measurement .....	12
3.4	Electrical Measurement .....	12
3.5	Power Output .....	13
3.6	Analogue Output .....	14
4	CALIBRATION .....	15
4.1	Procedure .....	15
5	OPTIONS .....	19
5.1	Pneumatics .....	19
5.2	Hydraulic Actuator Version .....	19
6	MAINTENANCE .....	21
6.1	General .....	21
6.2	Battery Replacement .....	21
6.3	Fuse Replacement .....	21
6.4	Fault Finding .....	24
6.5	Cleaning .....	25
6.6	Storage .....	25
7	HYDRAULIC ACTUATOR VERSION .....	27
7.1	Introduction .....	27
7.2	Specification .....	27
7.3	Hydraulic Oil Viscosity .....	29
7.4	Operation .....	29
7.5	Cleaning .....	35
7.6	Storage .....	35

---

**Contents (contd)****ILLUSTRATIONS**

Figure 1, Instrument Connections .....	6
Figure 2, Instrument Controls .....	8
Figure 3, Key-pad and Display .....	9
Figure 4, Battery Compartment .....	22
Figure 5, Internal Assembly .....	23
Figure 6, Hydraulic Actuator Version .....	28
Figure 7, Hydraulic Actuator Version Instrument Controls .....	30
Figure 8, Hydraulic Actuator Version Priming Accessories .....	31

**TABLES**

Table 1 Replacement fuses .....	24
Table 2 Error messages .....	24
Table 3 Suitable hydraulic oils .....	27
Table of pressure units and conversion factors .....	Rear cover

**1 INTRODUCTION**

The Druck DPI 601 instrument is a portable, pressure indicator and calibrator. The microprocessor-based instrument uses an internal transducer to measure and display pneumatic pressures applied to the connection port. The instrument also produces voltages for externally connected transducers and transmitters and measures the resulting outputs.

An input socket allows for the connection of a combined power supply and battery charger. Input and output sockets provide for the connection of external transmitters and transducers.

A pneumatic hand-pump, volume adjuster and vent valve may also be fitted as options to meet user requirements. A further option, the hydraulic actuator version, produces high pressure using specific fluids.

**1.1 Specification****Accuracy (integral transducers)**

Combined non-linearity, hysteresis and repeatability

70 mbar to 35 bar range .....	±0.05% FS
35 bar to 700 bar range .....	±0.1% FS
Maximum working pressure .....	150% FS

**Resolution**

Instrument <100 mbar FS .....	0.01% FS
Instrument >100 mbar FS .....	0.005% FS

**Dimensions**

Size .....	320 mm x 195 mm x 125 mm
Weight .....	4 kg nominal (changes with options fitted)

**Power Supplies**

Internal power .....	4 x Size D (IEC R20)
.....	zinc-carbon/alkaline/nickel-cadmium batteries
Usual battery life .....	50 hours (with no load on power output terminals)
Battery charging .....	nickel-cadmium batteries
.....	usual charge current 400 mA (14 hours)
External Power .....	3.5 to 14 Volts at 100 mA
.....	9 Volts DC at 500 mA
Power plug .....	2.1mm power plug, centre -ve supplying the
.....	instrument and recharging the nickel-cadmium batteries
Signal sockets .....	4 mm

**Environment**

Operating temperature .....	-10 to +50°C
Storage temperature .....	-20 to +60°C
Calibrated temperature .....	0 to +40°C
Pollution degree .....	2

**Temperature Effects**

SPAN (0°C to +40°C averaged referred to 23°C)

Gauge and differential .....	$\pm 0.006\%$ of reading/°C for 70 mbar to 60 bar
Gauge over 60 bar .....	$\pm 0.4\%$ FS
Absolute .....	$\pm 0.3\%$ FS

**Voltage Range**

Maximum input and read-out ..... 50V DC

**2V RANGE**

Accuracy .....	$\pm 0.07\%$ of reading $\pm 2$ digit *
Load current .....	200 nA max
Input resistance .....	10 M $\Omega$
Temperature stability .....	$\pm 0.0075\%$ of reading/°C $\alpha$

**20V RANGE**

Accuracy .....	$\pm 0.07\%$ of reading $\pm 2$ digit *
Load current .....	2 $\mu$ A max
Input resistance .....	10 M $\Omega$
Temperature stability .....	$\pm 0.0075\%$ of reading/°C $\alpha$

**50V RANGE**

Accuracy .....	$\pm 0.07\%$ of reading $\pm 2$ digit *
Load current .....	20 $\mu$ A max
Input resistance .....	10 M $\Omega$
Temperature stability .....	$\pm 0.0075\%$ of reading/°C $\alpha$

**Current Range**

Maximum input and read-out ..... 30mA  
DC

Accuracy .....	$\pm 0.1\%$ of reading $\pm 1$ digit *
Sense resistance .....	10 $\Omega$
Temperature stability .....	$\pm 0.0075\%$ of reading/°C $\alpha$

\* Over 90 days at calibration temperature

$\alpha$  Averaged over calibration temperature range

**Power Output**

Maximum combined load ..... 30  
mA

**+24V Output**

Accuracy .....  $\pm 5\%$   
Temperature stability .....  $\pm 0.02\%/^{\circ}\text{C}$

**+10V Output**

Accuracy .....  $\pm 0.1\%$   
(Adjustable by an internal potentiometer)  
Temperature stability .....  $\pm 0.005\%/^{\circ}\text{C}$

**Analogue Output**

Output ..... 2 Volts full-scale  
(calibrated to pressure scale S1)  
Bandwidth ..... 2kHz (-3db)  
Minimum load ..... 1000  $\Omega$   
Accuracy  
basic performance without compensation typically .....  $\pm 0.2\%$  FS  
Temperature error band .....  $\pm 0.5\%$  FS  
..... over calibrated temperature range 0 - 40°C  
Stability (over three months) .....  $\pm 0.02\%$  FS

**Note:** Continuing development sometimes necessitates specification changes without notice.



Blank page

## **2 INSTALLATION**

### **2.1 Power Supply**

The instrument can be powered from internal batteries or from an external supply.

#### **Internal Batteries**

Four 1.5V Size D batteries power the instrument. These can be either primary batteries or nickel-cadmium rechargeable batteries. An internal 500mA fuse protects the instrument against incorrect battery connection (i.e., reverse polarity). To replace the fuse follow the procedures in Section 6. The batteries will be charged if: external 9V supply is connected, link LK3 on the PCB is removed and the charge key is pressed.

#### **WARNING**

**DO NOT ATTEMPT TO CHARGE DRY CELL BATTERIES. TO AVOID ACCIDENTAL CHARGING, LINK LK3 IS FITTED WHEN DRY CELLS BATTERIES ARE USED.**

#### **CAUTION:**

- **Old batteries can leak and cause corrosion.**
- **Never leave run down batteries in the instrument.**

#### **External Supply (Figure 1)**

A combined power supply and battery charger supplying 9V at 500mA can be plugged into the socket labelled POWER at the rear of the instrument. An internal 1 amp fuse is fitted to protect the instrument circuits. To replace the fuse follow the procedures in Section 6.

#### **Power Output (Figure 1)**

#### **CAUTION:**

- **Do not exceed the maximum load.**
- **Do not short circuit the output sockets.**

The instrument supplies two DC power outputs. 24V and 10V DC supplies are available from the sockets labelled OUTPUT 24V, 10V and 0V. The voltage is fully floating and supplies a load of 20mA at each socket and a maximum combined load of 30mA.

## 2.2 Pneumatic Supply

### WARNING

**COMPRESSED GAS CAN, IN CERTAIN CIRCUMSTANCES, BE LETHAL. WHEN CONNECTING AND DISCONNECTING COMPRESSED GAS SUPPLY LINES, ENSURE THAT THE SOURCE PRESSURE IS TURNED OFF AND THE PRESSURE LINES ARE VENTED. PROCEED WITH CARE.**

#### Pneumatic Connection (Figure 1)

A single inlet port connection locates on the front of the instrument and is G1/8 (female) or 1/8" 27 NPT (female).

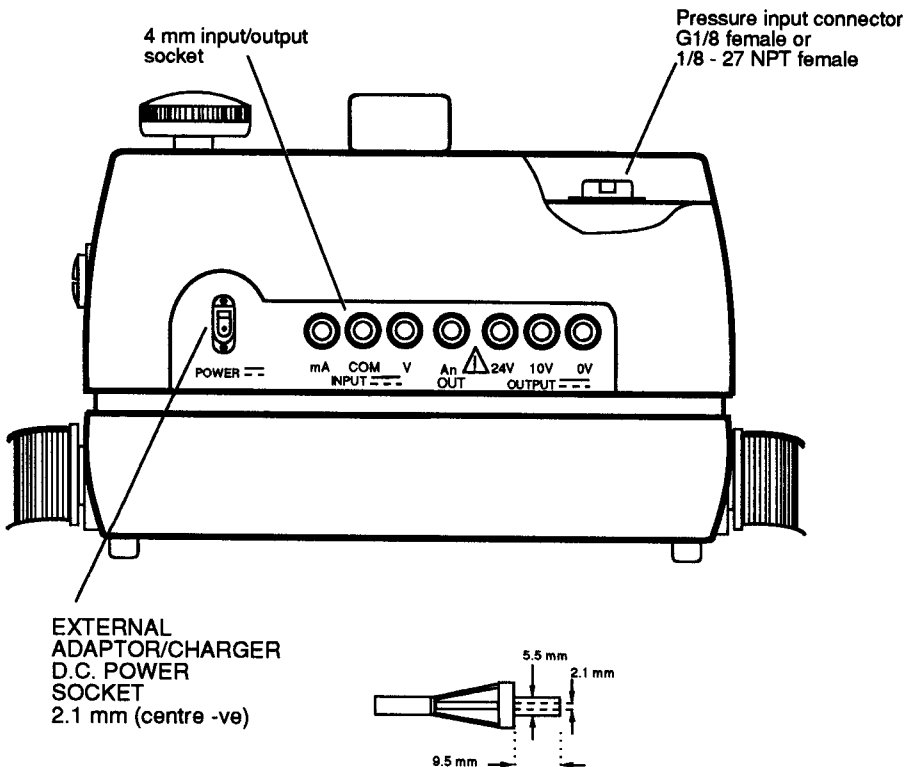

Figure 1, Instrument Connections

**3 OPERATION**

**3.1 Modes of Operation (Figure 2)**

The modes of operation are:

- ❑ Measuring pressure using the internal transducer.
- ❑ Supplying electrical excitation for external pressure transducers and transmitters and measuring the resulting electrical outputs.
- ❑ Generating pressure with the integral hand-pump (pneumatic option).
- ❑ Generating hydraulic pressure with the integral screw-press (hydraulic actuator version).

The following description of instrument operation refers to each key function.

**3.2 Key Functions (Figure 3)**



**Power ON/OFF key**

Press this key and the display shows all LCD segments and symbols, the instrument produces an audible tone for approximately 2 seconds. After the power-up routine the instrument always enters pressure scale S1. The microprocessor continuously monitors the keys. An audible tone acknowledges each key press, the instrument changes to the corresponding mode and display.



**Pressure Scale key**

Press one of the PRESSURE SCALE keys to change the units of pressure measurement, the display shows the measured pressure. The instrument is delivered with the three PRESSURE SCALE keys programmed to measurement units requested by the customer and chosen from the table on the rear cover.



**Volts key**

This key selects the external DC voltage input range. The 2/20/50V DC input is auto-ranged to give the best resolution. The voltage reading for the 2V range is X.XXXX, 20V range is XX.XXX and for 50V range XX.XX. The **V** symbol is shown on the display. There is no over-range indication for the 50 V range. Pressing a pressure scale key returns the instrument to pressure measurement. The following functions can be used in this mode: zero, peak, % and square root.

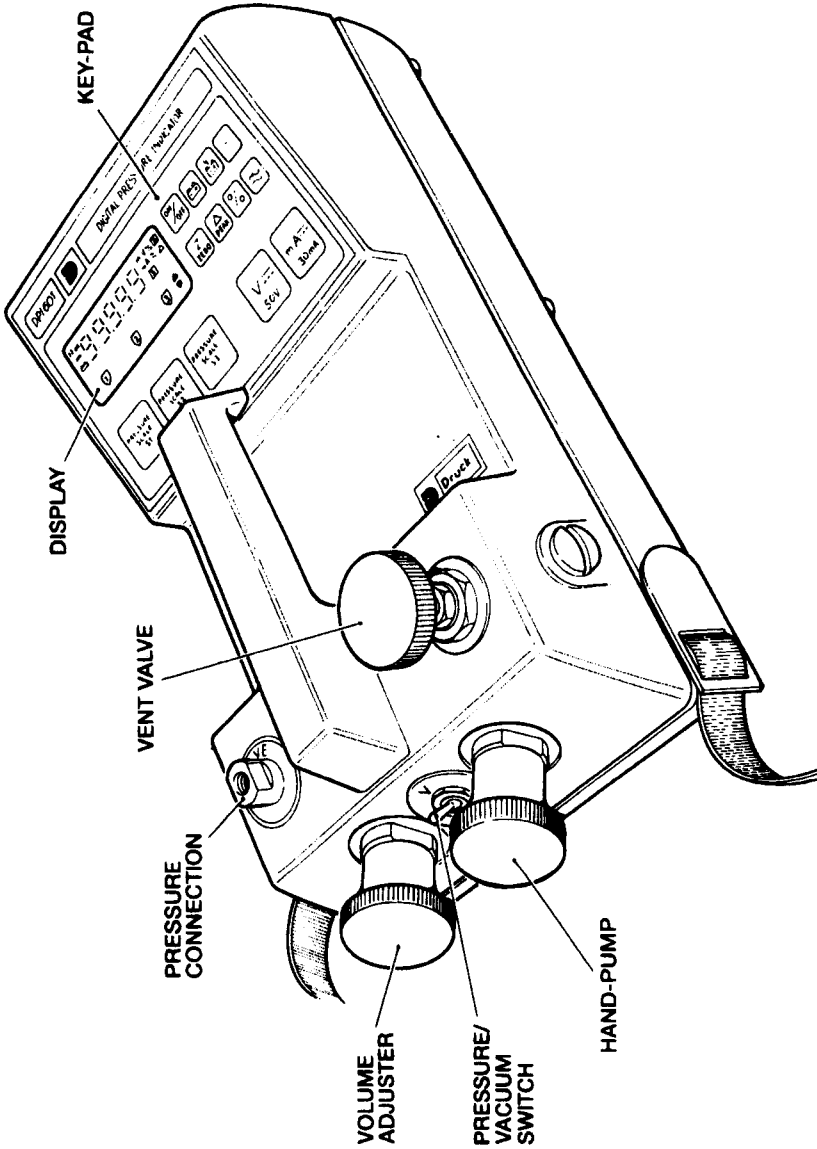

Figure 2, Instrument Controls

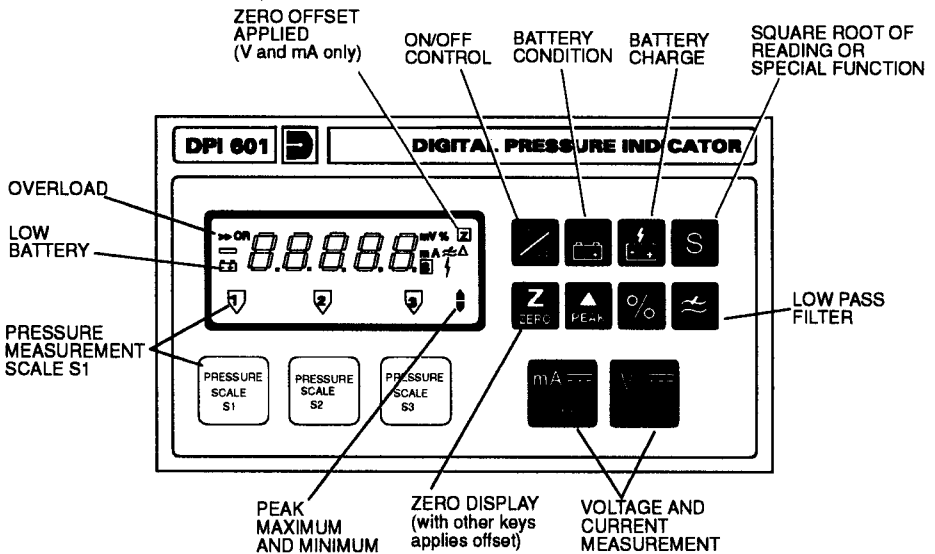

Figure 3, Key-pad and Display



**mA key**

Press the mA key to select the current measurement mode. The instrument measures and displays the DC current input, at the rear of the instrument, labelled INPUT mA and INPUT COM. The instrument can measure up to 30 mA maximum; an over-range input is indicated by a blank display and the **OR >>** symbol. Pressing a pressure scale key returns the instrument to pressure measurement. The following functions can be used in this mode: zero, peak, % and square root.



**Zero key**

When in the pressure measurement mode, press the ZERO key and one of the PRESSURE SCALE keys together and the instrument corrects for the transducer ZERO offset. The instrument subtracts the stored ZERO offset value from all subsequent pressure readings and displays the difference.

When in the voltage measurement mode, press the ZERO key and the instrument stores the voltage measurement value and the display shows zero. The instrument subtracts the stored voltage measurement value from all subsequent voltage readings and displays the difference. The display shows the **Z** symbol to indicate this function.

When in the current measurement mode, press the ZERO key and the instrument stores the current measurement value and the display shows zero. The instrument subtracts the stored current measurement value from all subsequent current readings and displays the difference. The display shows the **Z** symbol to indicate this function. When PEAK is selected, pressing the ZERO key resets the PEAK reading.

**Peak key**

Press the PEAK key, the display shows the maximum PEAK reading value together with the  $\Delta$  and a flashing  $\blacksquare$  symbol.

Press the PEAK key again and the display shows the minimum PEAK reading value together with the  $\Delta$  and a flashing  $\blacksquare$  symbol.

Press the PEAK key again and the PEAK function switches off. This function can be selected for pressure scales S1, S2 or S3 and electrical ranges V and mA.

**% key**

This key switches the % function on and off. The reading on the display is expressed as XXX.XX percent of full-scale. The display shows the % symbol. For pressure scales S1, S2 or S3, the full-scale = 100% and zero pressure = 0%. This can be varied to order, for instance 3 - 15psi, 0.2 - 1bar can be displayed as 0 - 100%. For VDC range 2V = 100% and 0V = 0%. For mA range 20mA = 100% and 4mA = 0%. This function can be selected for pressure scales S1, S2 or S3 or V or mA ranges. Selecting other ranges will not affect the function relevant to a particular range.

**Filter key**

This key switches the low pass filter function on and off. The fluctuating pressure reading is filtered and display shows the  $\approx$  symbol. The filter time constant is approximately 10 seconds for fluctuating pressure below 10% of full-scale. This function can be selected for pressure scales S1, S2 or S3. Selecting other ranges will not affect the function relevant to a particular pressure scale.

**Square Root key**

This key switches the square root function on and off. The display shows the square root of the reading and **S** symbol. This function can be selected for any of the pressure scales S1, S2 or S3 or electrical ranges V or mA. Selecting other ranges will not affect the function relevant to a particular range. For special order instruments the function of this key may be varied.

**Battery Condition key**

Press this key and the display shows the battery condition as a percentage value of full charge in the ranges:

0 - 25%

25 - 50%

50 - 75%

75 - 100%

The display also shows the BATTERY symbol. This symbol flashes if battery condition is below 25% of full charge. The selection of another mode cancels the battery condition function.

**Battery Charge key****WARNING****DO NOT ATTEMPT TO CHARGE DRY CELL BATTERIES**

To charge the rechargeable batteries, connect the 9V battery charger and press the key rechargeable batteries will now charge and the display shows the LIGHTNING symbol. Charging continues for approximately 14 hours and then automatically switches off.

**Note:** *Instruments without rechargeable batteries have link LK3 on the PCB fitted which disables the charge function.*



### 3.3 Pressure Measurement

The pressure measurement mode is selected by pressing the S1 or S2 or S3 key. The display shows the pressure applied at the pneumatic port. An over-pressure is indicated by an audible tone and the display showing **Err2** and flashing **OR>>**.

Pressing a pressure key and Z key together zeroes the display and stores the transducer offset. If the offset is outside the nominal range when the keys are pressed, the display shows **Err 3**. Check there is no pressure in the system or adjust internal coarse zero offset potentiometer RV6.

To convert to other units of pressure measurement see the table on the rear cover. In this mode the functions of low pass filter, peak, % and square root can be used.

### 3.4 Electrical Measurement

#### **CAUTION:**

**To avoid damage to the instrument:**

- ▶ **Use caution when working with DC voltages.**
- ▶ **Ensure test leads are in good condition.**
- ▶ **Always replace fuses with the correct type and rating.**
- ▶ **Do not exceed the maximum input limits.**

#### **Voltage Measurement**

The voltage measurement mode is selected by pressing V key. The external DC voltage to be measured is connected to the input sockets V (red) and COM (black). The 2/20/50V DC input is auto-ranged to give the best resolution on the display. There is no over-range indication for the 50V range. Functions zero, peak max/min, % or square root can be used in this mode.

**Current Measurement**

The current measurement mode is selected by pressing mA key. The external DC current to be measured is connects to the input sockets mA (Yellow) and COM (black). An over-range is indicated by a blank display and **OR>>** symbol on the display. In this mode the functions of zero, peak, % and square root can be used.

An internal 100mA fuse protects the instrument against over-current in the current range. To replace a fuse follow the procedures in Section 6.

**3.5 Power Output**

The instrument produces voltage and current for external transducers and transmitters.

Output	Socket	Load
24V 0V	Brown Green	20mA *
10V 0V	Blue Green	20mA *

\* *Maximum combined load 30mA. Overloading this output can affect instrument operation.*

**Note:** *Battery life can be extended by disconnecting the load from the circuit when not required.*

The outputs are floating. The +24 Volt output is protected by an internal 50 mA fuse. If an internal fuse blows refer to section 6 for fuse replacement instructions.

### 3.6 Analogue Output

The analogue option voltage of 2 Volts equates to the full-scale pressure of pressure scale S1.

Output	Socket	Load
An out Com	White Black	1000 $\Omega$ +

+ Minimum load

## **4 CALIBRATION (Figures 3 and 4)**

Calibration adjustment is carried out by adjusting the appropriate potentiometer located on the PCB.

The following equipment and materials are required.

**Note:** *Equivalent substitutes may be used.*

- Variable power source
- Pressure standard
- Digital multimeter (DMM)
- Varnish for locking variable resistors

### **CAUTION:**

► **The PCB is fitted with CMOS static sensitive devices.**

### **4.1 Procedure**

Calibration must be performed in the following sequence. Unscrew the six captive, cap-head socket screws (3 mm AF) in the rubber feet and remove the base to gain access to the PCB.

#### **Electrical calibration**

1. Switch on the instrument and select V DC range.
2. Connect a link between the input sockets V (red) and COM (black).
3. Check the display and, if necessary, adjust potentiometer RV7 for a reading of 0.0000.
4. Disconnect the link.
5. Connect a variable power source to the input sockets +ve to V (red) and -ve to COM (black).
6. Adjust the variable power source to approximately -2 volts; this is the full-scale value. Apply the voltage to the instrument.

7. Check that the instrument display value agrees with the applied voltage within the accuracy statement in the specification.
  - ▣ If the values do not agree proceed as follows:
    - i. Connect the DMM +ve to the test point marked V on the PCB and -ve on COM (black) input socket.
    - ii. Adjust potentiometer RV3 until the display reading agrees with the applied voltage within the accuracy statement detailed in the specification.
    - iii. Disconnect the DMM.

**Note:** *The 20 V and 50 V ranges should automatically be within the accuracy statement detailed in the specification.*

8. Select mA range and connect a link between the input sockets mA (yellow) and COM (black).
9. Check the display and, if necessary, adjust potentiometer RV8 for a reading of 0.000.
10. Disconnect the link.

**Note:** *The 30 mA range should automatically be within the accuracy statement.*

**Pressure calibration**

1. Select pressure measurement scale S1.
2. Connect the pressure standard to the input connector.
3. Connect the DMM +ve to output socket An OUT (white) and -ve on COM (black) input socket.
4. Adjust the pressure standard to zero pressure.
5. Check the display and, if necessary, adjust potentiometer RV6 for a reading of zero.
6. Check the reading of the DMM. If necessary, adjust potentiometer RV9 for a reading of zero.
7. Adjust the pressure standard to the full-scale pressure.
8. Check the displayed reading is within specification. If necessary, adjust potentiometer RV5 for the correct pressure reading.
9. Check the reading of the DMM. If necessary, adjust potentiometer RV10 for a reading of 2 Volts.
10. Disconnect the DMM.

**Note:** *The other two pressure scales and linearity error should automatically be within specification.*

11. Using varnish, lock RV3, RV4, RV5, RV6, RV7, RV8, RV9 and RV10.
12. Refit the base and secure with the six captive, cap-head socket screws (3 mm AF) in the rubber feet.

Blank page

**5 OPTIONS****5.1 Pneumatics**

The instrument can be fitted with a hand-pump, volume adjuster and vent valve or any combination of these items to allow for pressure generation. With the pneumatic system connected and the instrument in pressure measurement mode, close the vent valve and use the hand-pump to generate the required pressure. The volume adjuster screws in and out to make fine adjustments to the pressure. Additionally, a pressure/vacuum switch can be fitted with the hand-pump to generate pressure (20 bar max) or vacuum (-750 mbar gauge max). On instruments with pressure ranges up to 350 mbar a pressure relief valve, venting inside the case, is fitted protecting the transducer from over-pressure.

***Note:** To prolong seal life, it is recommended that the pressure/vacuum switch is only operated below 10 bar.*

**5.2 Hydraulic Actuator Version**

This version of the instrument provides manual generation of hydraulic pressure details are contained in section 7.



Blank page

## **6 MAINTENANCE**

### **6.1 General (Figures 4 and 5)**

Maintenance is carried out to ensure that the instrument remains in a serviceable condition. Absolute cleanliness of the work area, tools and equipment must be observed at all times.

### **6.2 Battery Replacement**

The batteries are located in a separate compartment in the base unit.

1. To gain access to the battery compartment unscrew the two screws securing the hinged lid.
2. Replace batteries and observe the correct polarity.

### **6.3 Fuse Replacement**

#### **CAUTION:**

- ▶ **The PCB is fitted with CMOS static sensitive devices.**
- ▶ **Always replace fuses with the correct type and rating.**

The instrument is protected by internal fuses located on the PCB. The fuses are identified on the PCB by the label FS with a number as follows:

- ❑ FS1, 100mA protects the instrument against over-current and FS1, spare fuse.
  - ❑ FS2, 1A fuse protects the instrument circuit.
  - ❑ FS3, 50mA fuse protects the power output.
  - ❑ FS4, 500mA fuse protects the instrument against incorrect battery connection (i.e., reverse polarity).
  - ❑ The battery compartment contains a fused link, 25 SWG rated at 15A, connected in series with the cells. The fused link protects the re-chargeable nickel-cadmium batteries against short-circuit.
1. Fuse  
Remove the base as detailed in to gain access to the PCB, replace the appropriate fuse. Refit the base and secure with the six captive, caphead socket screws (3 mm AF) in the rubber feet.

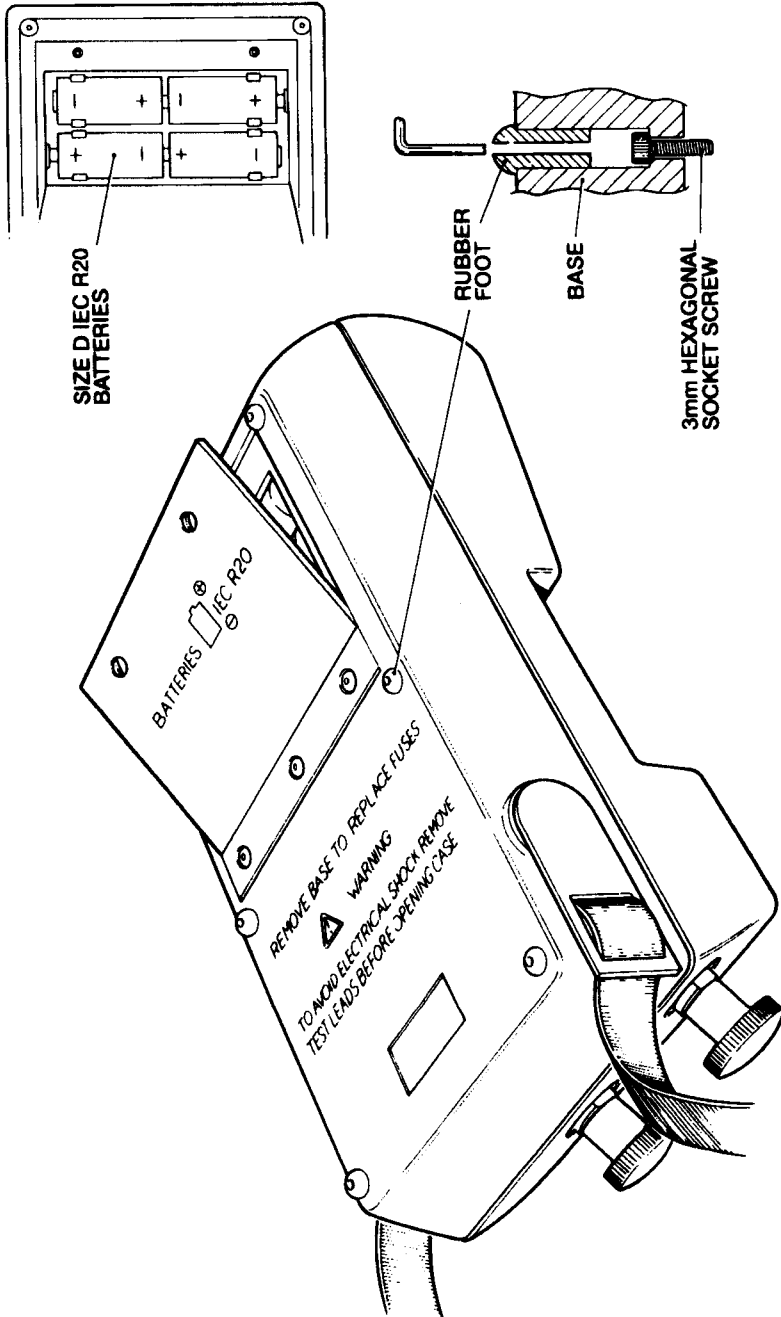

Figure 4, Battery Compartment

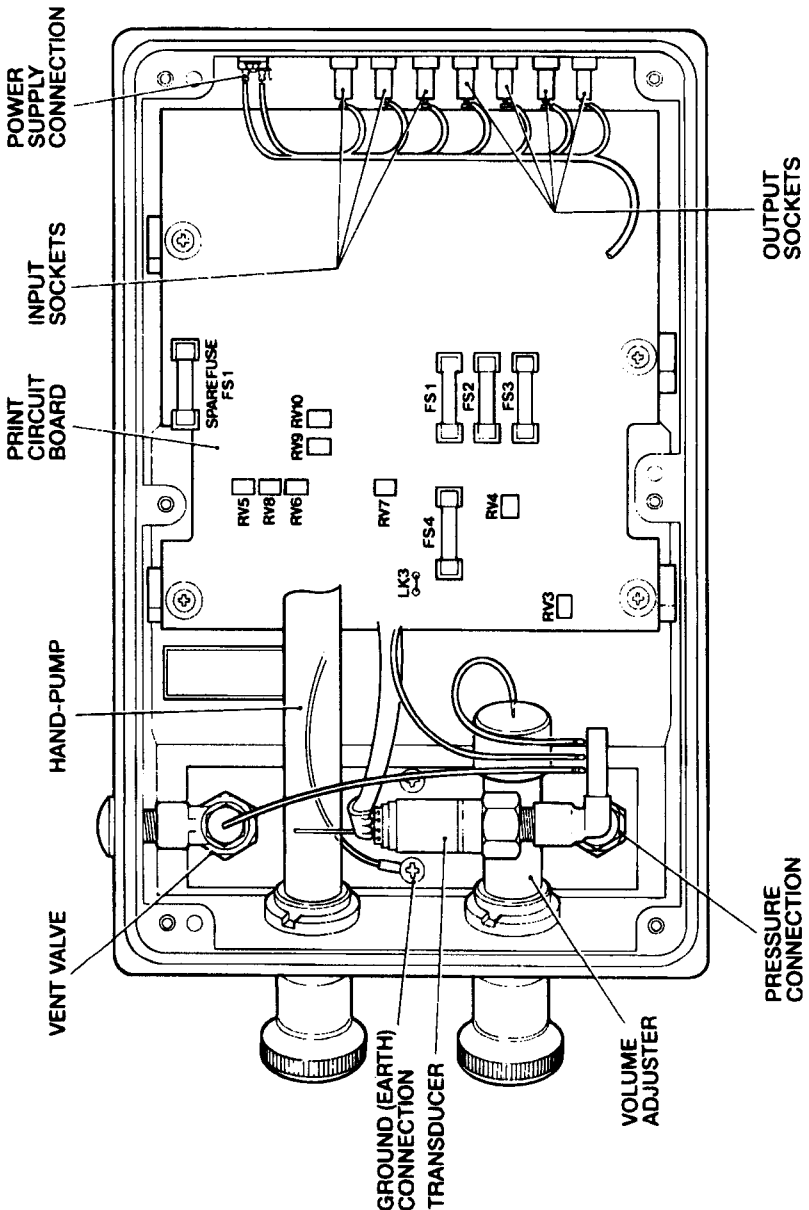

Figure 5, Internal Assembly

### 6.3 Fuse Replacement (contd)

#### 2. Fuse Link

The fuse link is 25 SWG (0.508mm) or 24 AWG (0.511mm) 15A wire linking the two sets of batteries in series. The link is soldered in position and protected with heat-shrink tubing.

Table 1, Replacement Fuses

Fuse No.	Description	Druck Part No.
FS 1	100 mA QUICK-BLOW	195-089
FS 2	1A ANTI-SURGE	195-054
FS 3	50 mA QUICK-BLOW	195-011
FS 4	500 mA ANTI-SURGE	195-014

### 6.4 Fault Finding

If an operating error condition exists, the instrument automatically generates an appropriate message shown on the display as Err X; where X is the error number.

The following table shows the error code displayed, the error condition and the remedial action.

Table 2, Error Messages

Display	Error condition	Remedy
err 0	-	No error
err 1	-	No error
err 2	Over-pressure	Reduce applied pressure
err 3	Zero outside the nominal range	Check that no pressure applied at pressure port, adjust RV6
err 4	-	No error
err 5	Illegal	Function not allowed

Replacement of parts, testing and further information is contained in the Druck service manual K129. Otherwise, if the instrument fails to perform to specification, return it to the manufacturer or approved agent.

## 6.5 Cleaning

Clean case with damp cloth and mild detergent.

## 6.6 Storage

**Note:** For the hydraulic actuator version and before this procedure, carry out the procedures detailed in section 7 the hydraulic actuator version section.

1. Before storage, access the battery compartment and remove the batteries (see 6.3).
2. The instrument must be stored in a dry, dust-free atmosphere, free from corrosive fumes which may damage the internal components
3. Storage must be in standard atmospheric pressure and humidity. The storage temperature range is detailed in paragraph 1.1.

Blank page

**7 HYDRAULIC ACTUATOR VERSION**

**7.1 Introduction**

This version of the DPI 601 instrument provides manual generation of hydraulic pressure and consists of a screw-press with a priming pump and priming shut-off valve.

The internal hydraulic parts are brass, stainless steel, copper, flourocarbon rubber (Viton). The hydraulic fluid must be compatible with the internal parts.

**7.2 Specification**

**TRANSDUCER**

Pressure ranges ..... 0 to 160 bar  
 ..... 0 to 400 bar  
 Over-range reading ..... 130% FS (nominal)  
 Resolution ..... 0.01% FS  
 Combined linearity, hysteresis and repeatability .....  $\pm 0.05\%$  FS

**HYDRAULIC SYSTEM**

Hydraulic volume ..... 17 cc (approx.)  
 Hydraulic fluid ..... demineralised water  
 or ..... one of the hydraulic oils listed in Table 3  
 Operating temperature ..... demineralised water +5 to +50°C  
 or ..... oil -10 to +50°C  
 Pressure connection ..... G1/8 Female  
 or ..... 1/8" NPT Female  
 Maximum working pressure ..... 130% FS

The following table gives the S.A.E. classification or equivalent only as guide to viscosity.

Table 3, Suitable Hydraulic Oils

ISO 3448 viscosity grade	Approx.SAE viscosity classification	Shell	Esso	Mobil
VG 10	5W	Tellus R10	Nuto H10	Velocite No. 6
VG 15	-	Tellus T15 Tellus V15	Nuto H15	-
VG 22	-	Tellus 22 Tellus R22	Nuto H22	DTE22
VG 32	10W	Tellus V32	Nuto H32	DTE Oil light DTE24
VG 37	-	Tellus 37 Tellus R37 Tellus T37 Tellus V37	-	-

**Note:** *Equivalent clean hydraulic fluid can be used, if in doubt consult Druck.*



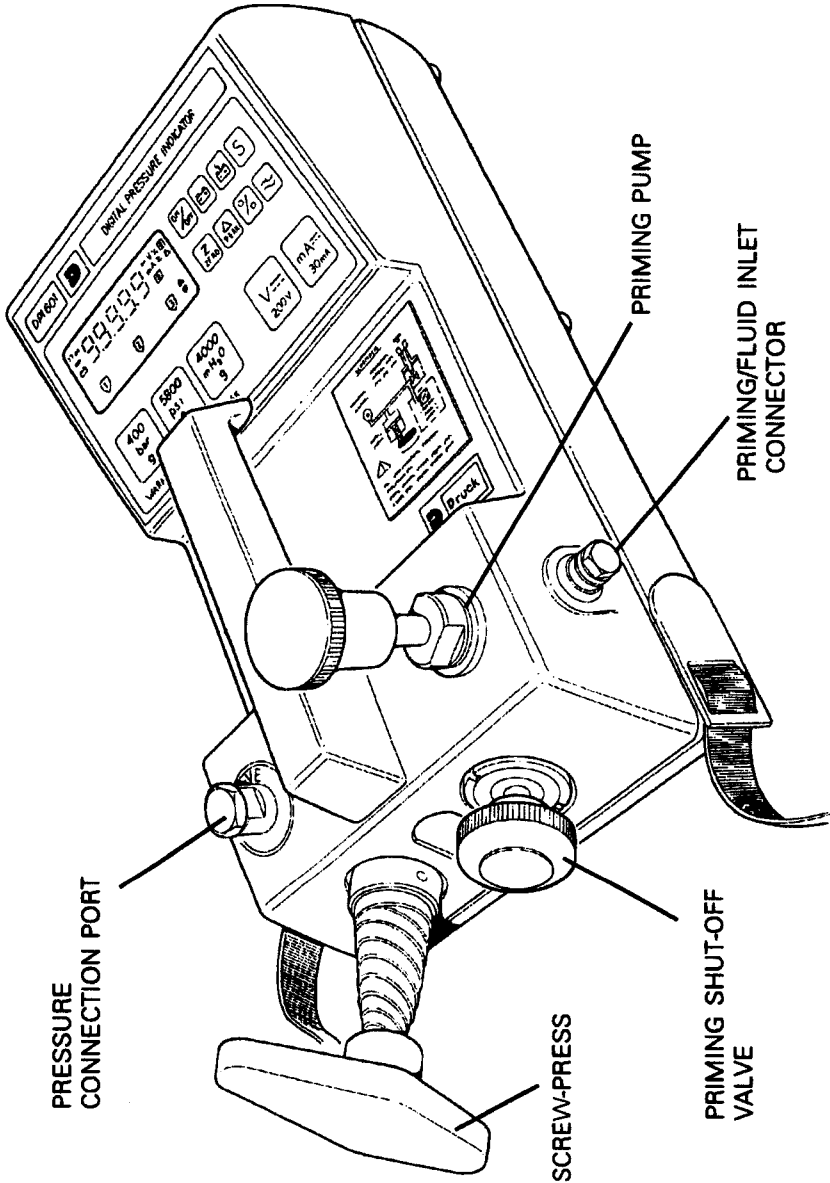

Figure 6, Hydraulic Actuator Version

## 7.3 Hydraulic Oil Viscosity

It is essential for good operation and accuracy of the instrument to use the correct hydraulic mineral oil of the appropriate viscosity. The more viscous oils give a low fall-rate at high pressures (i.e., above 100 bar), less viscous oils give increased sensitivity at low pressures. The recommended S.A.E. viscosity for general use is 10W.

## 7.4 Operation

**The following procedures must be carried out by a competent person.**

The instructions given in this section include the steps that must be carried out before and after use. The section contains information and warnings that must be followed to ensure the safe operation and maintain the instrument in a safe condition.

### WARNINGS

**HYDRAULIC FLUID IS INJURIOUS. OBSERVE RELEVANT HEALTH AND SAFETY PRECAUTIONS. USE APPROPRIATE PROTECTIVE BARRIERS AND EYE PROTECTOR.**

**BEFORE APPLYING PRESSURE, EXAMINE ALL FITTINGS AND EQUIPMENT FOR DAMAGE AND ENSURE THAT ALL EQUIPMENT IS TO THE CORRECT PRESSURE RATING.**

### CAUTION:

- **Observe absolute cleanliness when using this instrument. Severe damage can be caused if equipment connected to this instrument is contaminated. Connect only clean pressure gauges to the instrument. To avoid any contamination an external filter is recommended.**
- **Do not exceed the maximum working pressure stated in the Specification.**

### Preparation

1. Place the instrument on a horizontal surface.
2. Switch on the instrument and select the required units of measurement.
3. Connect the pressure gauge assembly (with a bleed valve) to be tested to the pressure connection port.
4. During the following operations prepare for fluid spillage, use a suitable receptacle for collecting the spillage.

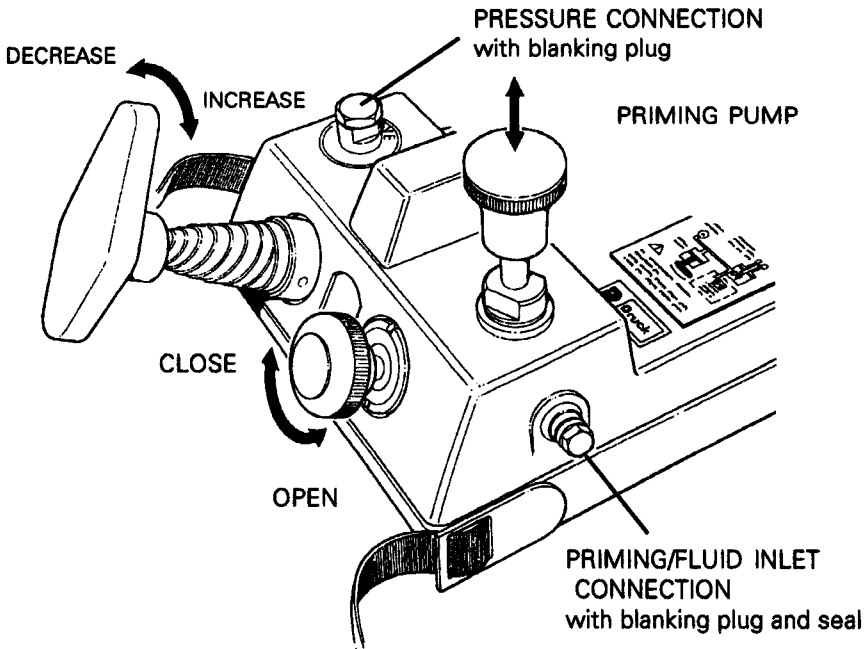

Figure 7, Hydraulic Actuator Version Instrument Controls

### Priming and Bleeding the System

The hydraulic system needs to be primed and bled free of air.

**Note:** *Demineralised water is used to test the instrument at manufacture. On shipment, the hydraulic assembly, will have traces of demineralised water in the system.*

#### CAUTION:

- ▶ **Do not mix hydraulic fluids.**
- ▶ **Use only recommended fluids.**

#### Priming the system (Figure 7 and 8)

1. Connect the pipe assembly, with a bonded seal, to the priming/fluid inlet connector. Locate the other end of the pipe in the fluid reservoir.

**Note:** *The reservoir must contain clean hydraulic fluid.*

2. Connect the other pipe assembly, with a bonded seal, to the pressure port. Connect the other end of this pipe assembly to the pressure gauge to be tested or if priming and bleeding the instrument locate the pipe end in the fluid of the reservoir.
3. Turn the priming shut-off valve knob anticlockwise to fully open the shut-off valve. Open the pressure gauge assembly bleed valve.
4. Turn the screw-press to the fully clockwise position.
5. Carefully push down the priming pump plunger to the bottom of the stroke or until fluid is seen coming out of the pressure port pipe assembly or the pressure gauge bleed valve.
6. Close the pressure gauge assembly bleed valve. If necessary, fill or top-up the reservoir with clean fluid.
7. Slowly turn the screw-press anticlockwise to draw fluid into the system; at the same time topping-up the reservoir making sure that fluid can always be seen in the reservoir. Continue until the screw-press is in the fully anticlockwise position.
8. Turn the priming shut-off valve knob clockwise to fully close the shut-off valve.

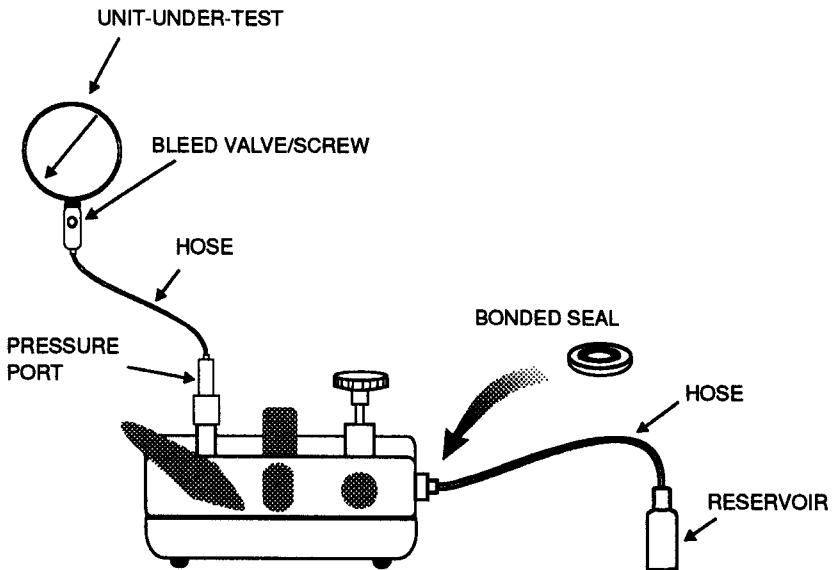

Figure 8, Hydraulic Actuator Version Priming Connections

Bleeding the systemNOTES

- 1: *If the reservoir empties of fluid, air will enter the system.*
- 2: *If the priming pump is operated without the reservoir connected or the reservoir empty air enters the system*
1. Slowly turn the screw-press clockwise to bleed the system free of air. Observe the hydraulic fluid coming out of the pipe assembly located in the reservoir, stop turning the screw-press when no air bubbles can be seen in the fluid.
2. When no air is seen in the fluid or if the screw-press is in the fully clockwise position, slowly turn the screw-press anticlockwise to draw fluid into the system.
3. If necessary, repeat the priming and bleeding operations until the fluid is free of air and the screw-press is fully anticlockwise.
4. When connecting the instrument to a system with pipe-work (i.e., with a large volume), fluid must be forced into the system. Proceed as follows:
  - i. Connect the pressure port pipe assembly to the system.
  - ii. Open the bleed screw or connection to prime the system.
  - iii. Turn the priming shut-off valve knob anticlockwise to fully open the shut-off valve. Push down the priming pump to force fluid into the system until fluid is seen coming out of the bleed screw or connection.
  - iv. If the priming pump is pushed to the fully down position without fluid being seen at the bleed screw or connection, more fluid is required.
  - v. Close the bleed screw or connection and open the priming valve. Carefully pull up the priming pump plunger and at the same time top-up the reservoir making sure that fluid can always be seen in the reservoir. Repeat the operations until the system is primed.
  - vi. When the system is fully primed, it must be bled using the bleed screw or connection. Proceed with the following:
5. Open the pressure gauge assembly bleed valve and slowly turn the screw-press clockwise to bleed the system observe fluid coming out.

6. Close the bleed valve when no air is seen in the fluid coming out of the bleed valve or if the screw-press is in the fully clockwise position. Slowly turn the screw-press fully anticlockwise to draw fluid into the system.
7. If necessary, open the bleed valve and repeat operations 5 and 6 until the system is free of air and the screw-press is in fully anticlockwise position. Turn the priming shut-off valve knob clockwise to fully close the shut-off valve.
8. Close the pressure gauge assembly bleed valve.
9. Disconnect the priming pipe assembly and remove the reservoir.

**Note:** *Do not pull up the knob of the priming pump plunger as air may enter the system.*

10. For gauge instruments, carry out a zero of the instrument as detailed in the operation section of the manual.

### Pressure readings

1. Turn the screw-press clockwise to generate pressure and anticlockwise to reduce pressure. When taking a pressure reading make sure that the reading is sufficiently stable.

### NOTES

- a. *When hydraulic fluid flows through a restriction there is an increase in temperature that affects the pressure of the fluid. Allow sufficient time for the reading to stabilize.*
  - b. *A pressure drop or fall rate depends on the viscosity of the hydraulic fluid Table 1. A leak rate can be expected, typically 0.3bar/10sec at 350 bar.*
  - c. *If the instrument is taken from one environmental condition to be used in another, changes in temperature will affect the pressure reading. Allow sufficient time for the instrument's hydraulic system to attain ambient temperature.*
2. When the test is complete reduce the pressure in the system to zero by turning the screw-press fully anticlockwise then turn the shut-off valve anticlockwise.
  3. Remove the pressure gauge assembly.
  4. Fit the blanking plug to the pressure connection port.
  5. Carry out storage procedures.

## Replenishing or Changing Hydraulic Fluid

If the hydraulic fluid needs replenishing or changing proceed as follows:

### Emptying the system

1. Remove the blanking plug from the pressure connection port.
2. Turn the shut-off valve fully clockwise. Turn the instrument onto the side (pressure connection port nearest workbench). Place receptacle below the pressure port connection to collect hydraulic fluid.
3. Drain the system by slowly depressing the priming pump plunger. Turn screw-press fully clockwise.

### Flushing

If necessary, flush the system to remove any contaminants.

- a. With priming pump plunger fully depressed, turn the shut-off valve anticlockwise and connect the priming pipe assembly.
- b. Refill the priming pump reservoir with clean hydraulic fluid of the same type as the original fluid. Lift up priming pump plunger and unscrew fully anticlockwise the screw-press make sure the reservoir is always full of hydraulic fluid.
- c. Empty the system again and, if necessary, repeat the flushing operation until all the contaminants are removed.

After draining, dry the system.

**Note:** *Dry, compressed air is recommended for this operation. Obey local safety regulations when using compressed air.*

### Filling the system

1. Fill the system with clean hydraulic fluid via the prime pump reservoir.

**Note:** *The instrument system volume is approximately 17 cc.*

**7.5 Cleaning**

For instruments using approved hydraulic oil, clean the case, instrument controls with lint-free cloth and white spirit.

**7.6 Storage**

1. Empty the system then dry the system.
2. Refit the pressure connection blanking plug.
3. Fit the priming pump blanking connection and seal to the priming pump connector.
4. For further details of storage see paragraph 6.6.



Blank page